



# **EC-300**

*Audible Visual Emergency Call System*

## **INSTALLATION and OPERATION MANUAL**

---

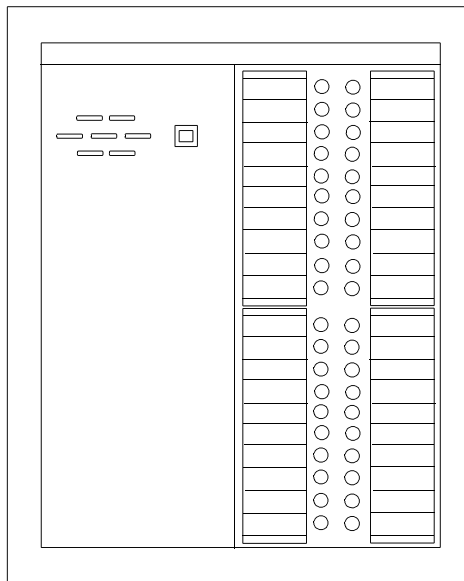

---

### **L NOTICE**

All information, documentation, and specifications contained in this manual are subject to change without prior notice by the manufacturer.

TABLE OF CONTENTS

	PAGE
1.0 INTRODUCTION .....	1
2.0 INSTALLATION .....	1
2.1 PATIENT STATION .....	1
2.2 EMERGENCY STATION .....	1
2.3 CORRIDOR LAMPS (DOME LIGHTS) .....	1
2.4 CENTRAL NURSE'S STATION .....	2
2.5 OTHER DEVICES .....	2
3.0 SYSTEM OPERATION: .....	3
3.1 STANDARD VISUAL CALL .....	3
3.2 DISTINGUISHABLE ALARM STATES, NORMAL AND EMERGENCY .....	4
3.3 NORMAL AND EMERGENCY CALL WITH SUBSEQUENT ALARM .....	4
3.4 SUBSEQUENT ALARM USING EC-103 AND EC-115 STATIONS .....	5
PANEL SPECIFICATIONS AND POWER CONSUMPTION CHART .....	6
4.0 WIRING DIAGRAMS	
NON-SUBSEQUENT ALARM SINGLE STATE ALARM USING EC-100 SUITE STATIONS .....	7
NON-SUBSEQUENT, DUAL STATE ALARM USING EC-100 ROOM STATIONS .....	8
NORMAL AND EMERGENCY CALL WITH SUBSEQUENT ALARM .....	9
SUBSEQUENT ALARM USING EC-103 AND EC-115 STATIONS .....	10
WARRANTY .....	11

## **1.0 INTRODUCTION**

The Mircom EC-300 Emergency Call System provides the common features and functions demanded by engineers and contractors. Over the years, nurse call systems have become increasingly complicated and expensive. Mircom's EC-300 system offers a basic system most nurses and administrators feel is necessary.

The EC-300 has been designed for easy operation so few instructions are required for staff to learn and essentially no training is required.

All "Emergency Calls" are indicated by a fast pulsing audible/visual indication which overrides "Normal" calls of slow pulsing audible/visual indications. All calls can only be cancelled at the point of activation. The nurse's station shall be able to momentarily silence for periods of 10, 5, or 2.5 minutes.

Easy maintenance is obtained on the Mircom system due to its modular construction. All components including the annunciator panels consists of modular panels for fast servicing and trouble-shooting.

Reliable, solid state construction on the EC-300 system provides trouble-free usage. The audible alarms are solid state for long term reliability unlike electro-mechanical devices such as buzzers or chimes. All annunciator lights are long life, high intensity, wide angle, light emitting diodes (LEDs).

Flexibility of the system is easy, due to the modular construction. The Emergency Call system and Door Monitoring can often be combined into the same housing. Blank panels can be provided to be replaced in any future expansion.

System components on a typical system usually include patient stations, emergency stations, corridor lights and central nurse's station. This manual will outline each and their various functions.

## **2.0 INSTALLATION**

Before any wiring is done to the system components, check all wires for opens, shorts or grounds, using an ohmmeter.

### **2.1 PATIENT STATION**

The EC-100 or EC-103 Pull Cord Station are normally mounted next to the patient's bed. All stations have a brushed stainless finish.

#### **EC-100 Pull Cord Station**

The pull cord station is equipped with a 6 foot, white nylon cord easily cut to required lengths. These cords when pulled operate a switch at the cord station. To reset the patient call, move the switch (at the pull cord station) to the upward position. Use this station in non-subsequent alarm systems.

#### **EC-103 Pull Cord Station with LED**

The pull cord station is equipped with a 6 foot, white nylon cord and a red confirmation LED. The cords when pulled operate a switch at the station which triggers the LED to illuminate. To reset the patient call, move the switch (at the pull cord station) to the upward position.

### **2.2 EMERGENCY STATION**

By wiring configuration of the EC-103 Pull Cord Station, the station can be programmed for "Emergency" status calls.

### **2.3 CORRIDOR LAMPS (DOME LIGHTS)**

The Corridor lamps are normally mounted above the doors of all rooms equipped with any type of station. The corridor lamps have a brushed stainless steel finish with a white plastic wedge shape lens. The lamps mount onto a standard single gang electrical box. Pressing the lens on top and bottom will unhook the lens from the plate. Replacement bulbs; use #1820, 24V.

#### EC-104 DOME LIGHT

The EC-104 is equipped with one clear incandescent bulb. The light illuminates whenever the suite station initiates a call to provide a visual signal in the corridor.

#### EC-106 DUAL DOME LIGHT

The EC-106 is equipped with two clear incandescent bulbs divided by a barrier strip, top and bottom. The top light illuminates whenever an Emergency station initiates a call. (Consult our factory, if coloured bulbs are required)

### **2.4 CENTRAL NURSE'S STATION**

The Central Nurses' Console is normally located within easy reach of operating personnel. The console houses the central control and annunciator panels. The console can either be flush or surface mounted. Each console consists of a backbox, frame, modular annunciator panels and the central call receiver panel.

**NOTE:** When local bylaws do not allow audible patient calls to be silenced at the console, the 'disable silence' jumper must be cut on the EC-300 Call Receiver Panel.

All console modular panels are made from extruded aluminum and secured to the 300 Series frame by two screws. The following are the available console panels.

#### EC-300 CALL RECEIVER PANEL

The EC-300 is the electronic central control board. All wiring is terminated to this panel excluding the selective room wiring which terminates on the annunciator panels. Connections are made to the EC-300 to determine the type of system operation and various flash rates. All peripheral devices such as Corridor horns and Duty stations terminate to the EC-300.

#### EC-220A ANNUNCIATOR PANEL

The EC-220A has 20 red LEDs to annunciate suite alarms. Each LED has a directory which can be typed with the room number.

#### EC-240A ANNUNCIATOR PANEL

The EC-240A has 40 red LEDs to annunciate suite alarms. Each LED has a directory which can be typed with the room number.

#### EC-000 BLANK PANEL

Ideal for installations which are built in phases. The EC-000 accommodates one standard panel space which can be replaced in the future with an annunciator.

#### TR-074B TRANSFORMER, 24 VAC, 75 VA

The TR-074B is a low voltage transformer used for all the power requirements of the EC-300 system.

### **2.5 OTHER DEVICES**

#### EC-105A CORRIDOR HORN

The EC-105A is a 24 Volt AC/DC horn to audibly annunciate alarm calls. Made from brushed stainless steel, the EC-105A mounts onto a standard two gang electrical box.

#### EC-140 DOME ALARM

The EC-140 mounts onto a single gang electrical box. Made from brushed stainless steel, the Corridor lamp includes a 24 V DC electronic piezo.

EC-300 CALL RECEIVER PANEL SPECIFICATIONS: (See Figure 1, Page 6)

Terminals :

L1	Current sense input, used on non-subsequent alarm installations. <b>CAUTION:</b> Do not connect this terminal directly to ground.
FL1	Slow flashing tripper input.
FL2	Slow flashing output (normally closed) contact which is connected to ground.
FL3	Fast flashing trigger input.
FL4	Fast flashing output (normally closed) contact which is connected to ground.
TRIG	Trigger input for 'subsequent' alarm systems. Only EC-103 pull cord stations can use this input.
+	Positive 24 volt output for peripheral devices.
-	Negative 24 volt output for peripheral devices.
T1,T2	Power supply input, 24 V AC
+SPK - SPK	External speaker outputs for duty stations.
Z1, Z2	Normally open SPST contact for exterior devices. Rated at 3 amperes, 24 volts. Contact releases on 'Signal Silence'.
RT	Remote Alarm output which can be silenced.
RR	Remote Reset input to remotely silence the EC-300 system.
RA	Remote Alarm output which cannot be silenced until all alarm conditions have been reset.

**CALL BACK FEATURE:**

To prevent staff from forgetting a call previously silenced, a time-out call back feature is available. A selectable DIP switch on the EC-300 Call Receiver board will re-activate the audible alarm within 2.5, 5 or 10 minutes.

**3.0 SYSTEM OPERATION:**

Various system operations are obtainable with the EC-300 control. Typical system drawings are attached for the common installations. Consult our Application Engineering department for system operations not outlined in this manual.

**3.1 STANDARD VISUAL CALL (WIRING DIAGRAM ON PAGE 7)**

Products Required:

EC-100	Pull Cord Station
EC-104	Corridor Lamp
EC-300	Call Receiver Panel
EC-220A	20 LED Annunciator Panel
EC-240A	40 LED Annunciator Panel
PS-3B	Transformer, 8/16/24 Volt taps
300-nF	Frame
300-nB	Backbox

Operation:

A Pull Cord Station (Model EC-100) when pulled, will activate its corresponding Corridor Dome Lamp (EC-104), annunciator LED and the audible alarm on the Call Receiver Panel (EC-300)

The visual and audible pulse rate can be selected by connecting 'line 1' to FL1 (Slow Flash), FL3 (Fast Flash) or - (Steady).

All incoming calls can be silenced from the central EC-300 call receiver panel. Subsequent calls without being reset, will **not** re-activate the audible alarm. All calls must be reset before the audible alarm will re-activate. To reset a call, the pull cord station must be placed in its original position, by pushing the call switch up. No calls can be reset at the central monitoring location without verifying the call.

### 3.2 DISTINGUISHABLE ALARM STATES, NORMAL AND EMERGENCY (WIRING DIAGRAM ON PAGE 8)

Products Required:

EC-100 Pull Cord Station

EC-104 Corridor Lamp

EC-300 Call Receiver Panel

EC-220A 20 LED Annunciator Panel

EC-240A 40 LED Annunciator Panel

PS-3B Transformer, 8/16/24 Volt tap

300-nF Frame

300-nB Backbox

Operation:

A 'normal' patient call will flash the room Corridor and annunciator lamp at a slow rate. A corresponding audible tone will be heard at the EC-300 Call receiver panel.

An 'emergency' patient call will flash the room Corridor and annunciator lamp at a fast rate. A corresponding audible tone will be heard at the EC-300 Call receiver panel. All 'emergency' patient calls in the same room will override 'normal' calls.

All incoming calls can be silenced from the central EC-300 call receiver panel. Subsequent calls without being reset, will **not** re-activate the audible alarm. All calls must be reset before the audible alarm will re-activate. To reset a call, the pull cord station must be placed in its original position, by pushing upwards the call switch. No calls can be reset at the central monitoring location without verifying the call.

### 3.3 NORMAL AND EMERGENCY CALL WITH SUBSEQUENT ALARM (WIRING DIAGRAM ON PAGE 9)

Products Required

EC-103 Pull Cord Station with Confirmation LED

EC-106 Corridor Lamp with two lamps

EC-300 Call Receiver Panel

EC-220A 20 LED Annunciator Panel

EC-240A 40 LED Annunciator Panel

PS-3B Transformer, 3/16/24

300-nF Frame

300-nB Backbox

Operation:

A '**normal**' patient call will flash the room Corridor and annunciator lamp at a slow rate. A corresponding audible tone will be heard at the EC-300 Call receiver panel.

An '**emergency**' patient call will flash the room Corridor and annunciator lamp at a fast rate. A corresponding audible tone will be heard at the EC-300 Call receiver panel. All 'emergency' patient calls in the same room will be distinguishable by the faster audible and visual pulse rate.

All incoming calls can be silenced from the central EC-300 call receiver panel. Subsequent calls will re-activate the audible alarm, without being reset. To reset a call, the pull cord station must be placed in its original position, by pushing the call switch up. No calls can be reset at the central monitoring location without verifying the call.

### 3.4 SUBSEQUENT ALARM USING EC-103 AND EC-115 STATIONS (WIRING DIAGRAM ON PAGE 10)

#### Products Required

EC-103	Pull Cord Station with Confirmation LED
EC-115	Bedroom Station
EC-106	Corridor Lamp with two lamps
EC-300	Call Receiver Panel
EC-220A	20 LED Annunciator Panel
EC-240A	40 LED Annunciator Panel
PS-3B	Transformer, 3/16/24
300-nF	Frame
300-nB	Backbox

#### Operation:

A **'normal'** patient call will flash the room Corridor and annunciator lamp at a slow rate. A corresponding audible tone will be heard at the EC-300 Call receiver panel.

An **'emergency'** patient call will flash the room Corridor and annunciator lamp at a fast rate. A corresponding audible tone will be heard at the EC-300 Call receiver panel. All 'emergency' patient calls in the same room will be distinguishable by the faster audible and visual pulse rate.

All incoming calls can be silenced from the central EC-300 call receiver panel. Subsequent calls will re-activate the audible alarm, without being reset. To reset a call, the pull cord station must be placed in its original position, by pushing the call switch up. No calls can be reset at the central monitoring location without verifying the call.

FIGURE 1:

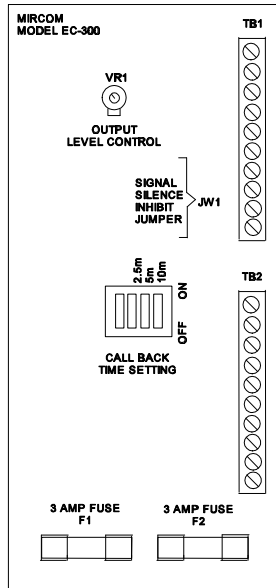

VR1  
THIS CONTROLS THE VOLUME OUTPUT TO THE INTERNAL/EXTERNAL SPEAKER.

JW1  
WITH JUMPER IN, ALARM TONES CAN BE SILENCED.  
WITH JUMPER REMOVED, ALARM TONES CAN **NOT** BE SILENCED.

CALL BACK  
SELECT ONLY ONE SETTING AT A TIME; 2.5m, 5m OR 10m WHICH REPRESENTS A CALL BACK DURATION OF 2.5 , 5 OR 10 MINUTES RESPECTIVELY.  
THIS CONTROL WILL RE-ACTIVATE THE ALARM TONES AFTER THE PRE-SELECTED TIME DELAY HAS EXPIRED.

F1 AND F2  
CONTROL UNIT FUSES. REPLACE ONLY WITH MAXIMUM 3 AMP, 250V TYPE

**POWER CONSUMPTION CHART**

ITEM	VA
EC-300 CALL RECEIVER	4
EC-104 DOME LIGHT	4
EC-220/240 EACH ILLUMINATED LED	0
EC-105DC HORN	5



**EC-300**

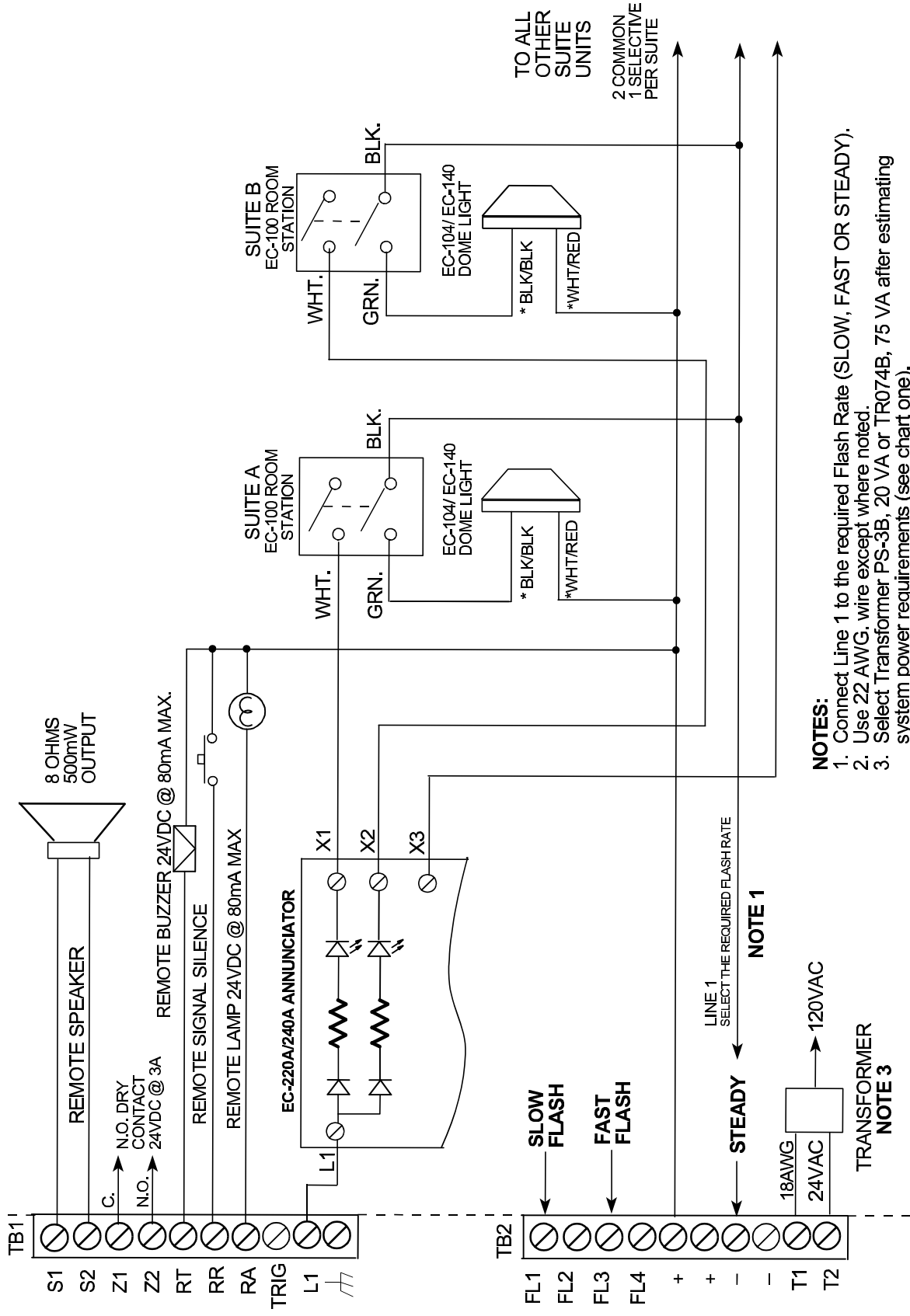

- NOTES:**
1. Connect Line 1 to the required Flash Rate (SLOW, FAST OR STEADY).
  2. Use 22 AWG, wire except where noted.
  3. Select Transformer PS-3B, 20 VA or TR074B, 75 VA after estimating system power requirements (see chart one).
- \* when using an EC-140 Dome Light and buzzer tie together the two black wires and tie the white and red wires together.

**EC-300**

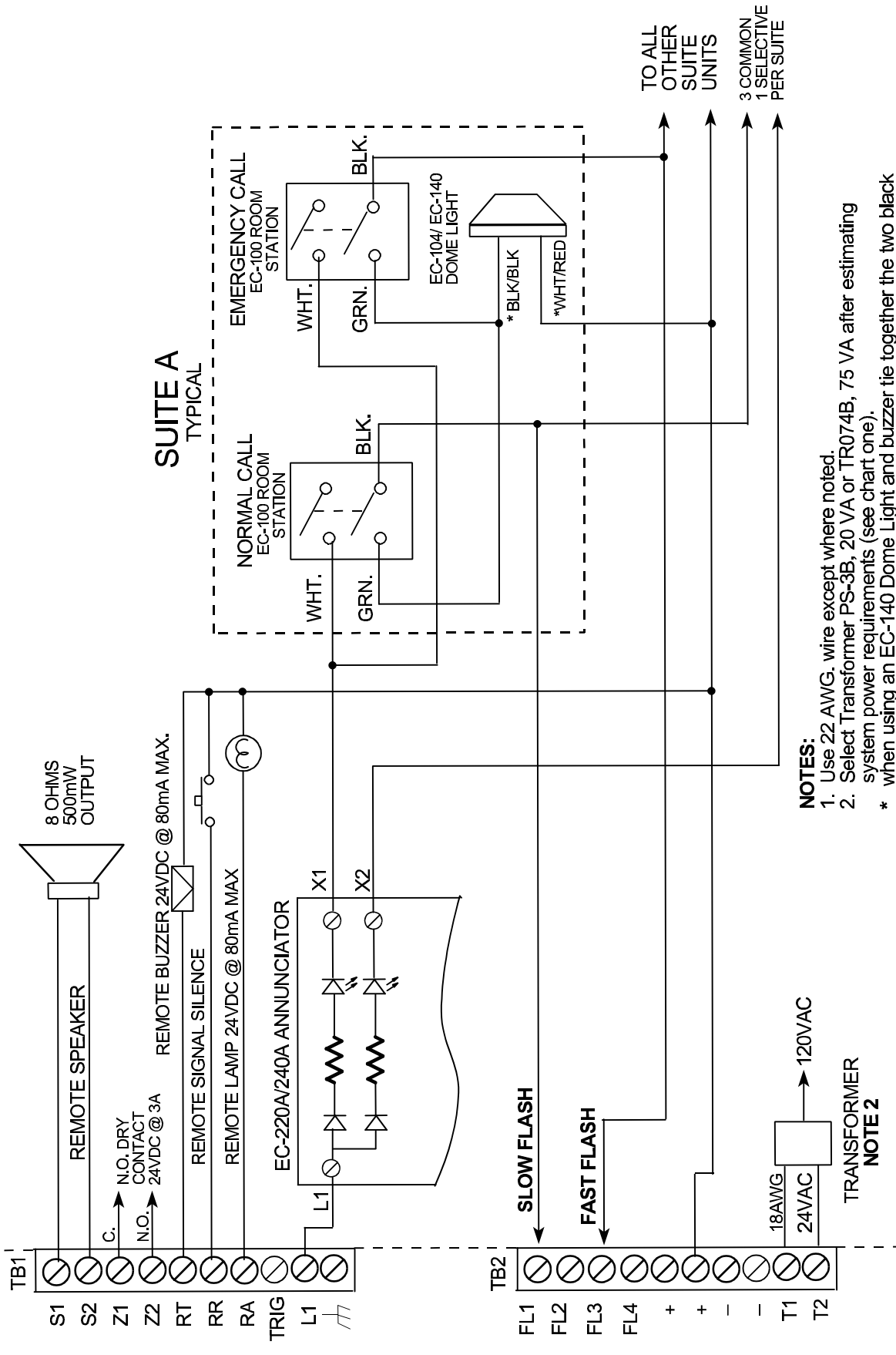

**NOTES:**

1. Use 22 AWG. wire except where noted.
  2. Select Transformer PS-3B, 20 VA or TR074B, 75 VA after estimating system power requirements (see chart one).
- \* when using an EC-140 Dome Light and buzzer tie together the two black wires and tie the white and red wires together.

TRANSFORMER  
NOTE 2

**EC-300**

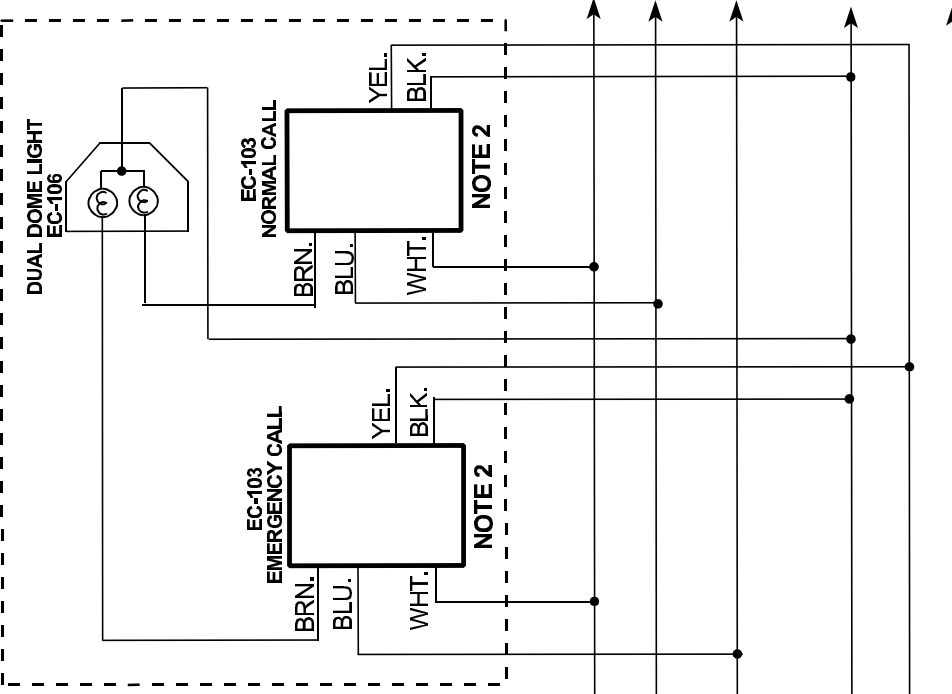
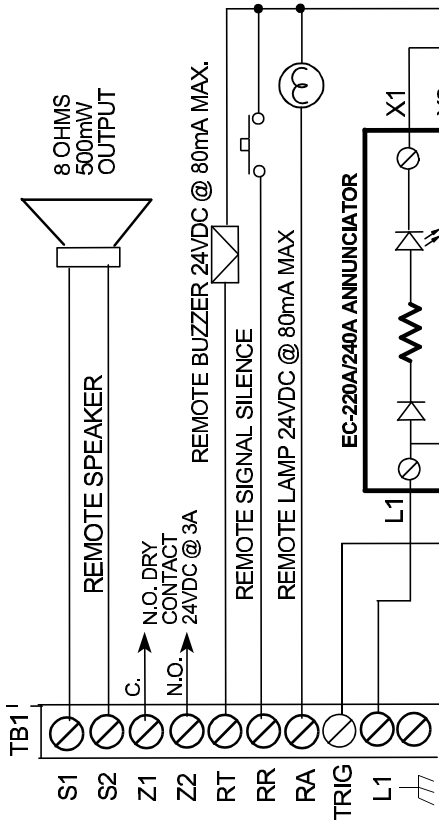

**SUITE A**  
TYPICAL

- NOTES:**
1. Use 22 AWG. wire except where noted.
  2. Cut orange and grey jumper on EC-103 station.
  3. Select Transformer PS-3B, 20 VA or TR074B, 75 VA after estimating system power requirements (see chart one).



**EC-300**

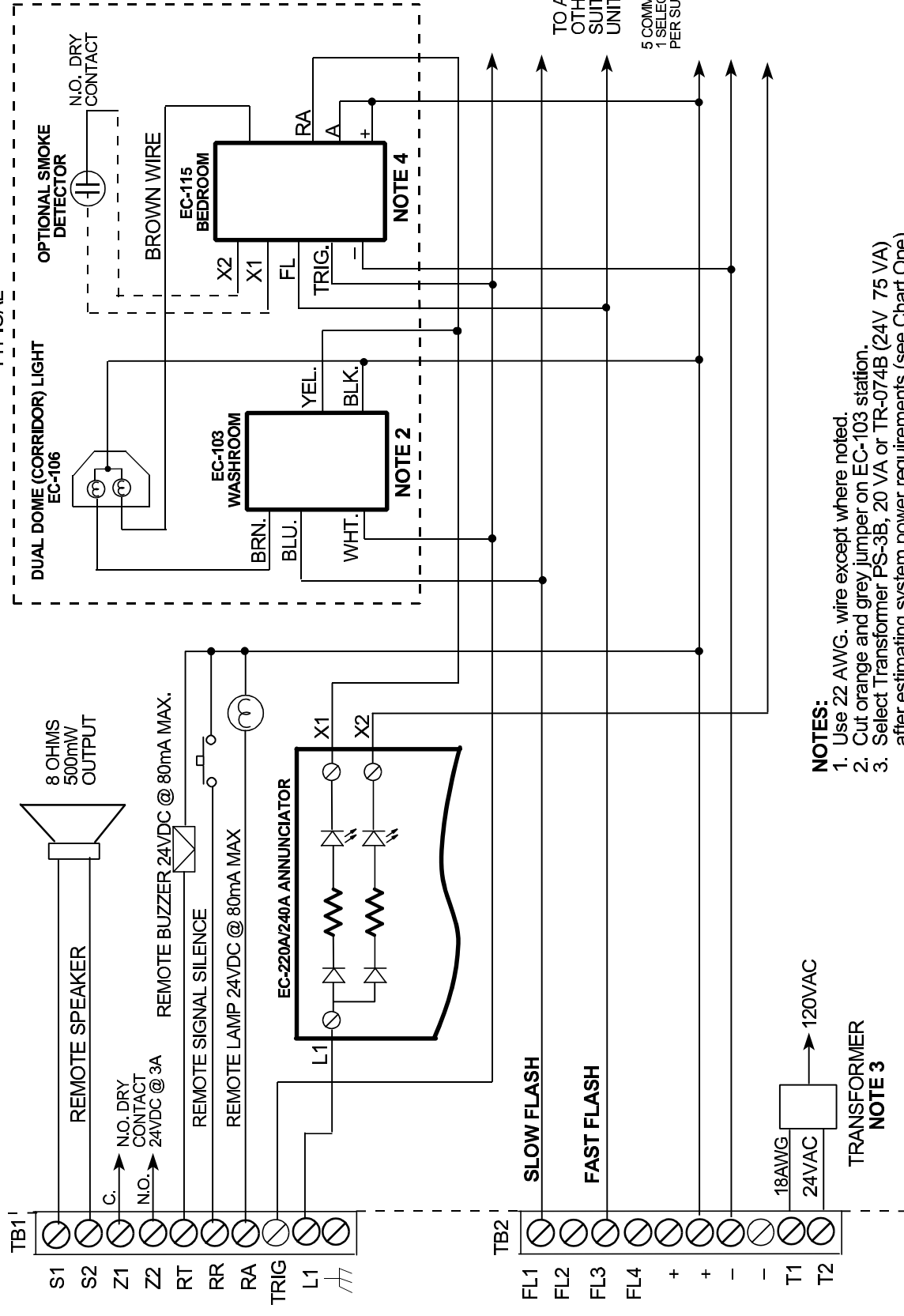

**SUITE A**  
TYPICAL

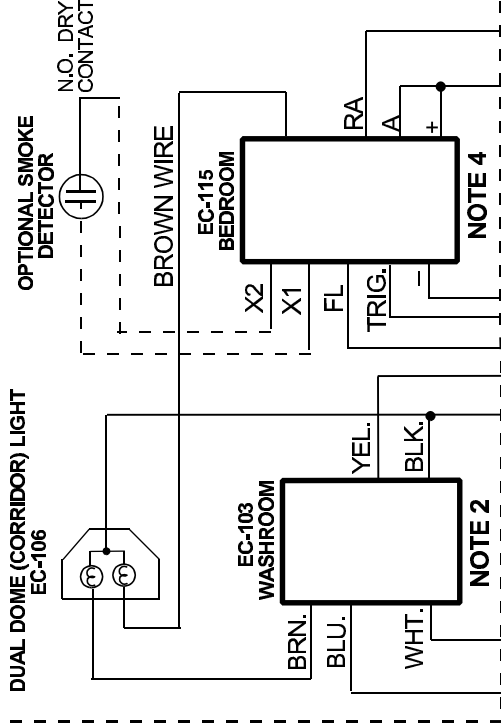

- NOTES:**
1. Use 22 AWG. wire except where noted.
  2. Cut orange and grey jumper on EC-103 station.
  3. Select Transformer PS-3B, 20 VA or TR-074B (24V 75 VA) after estimating system power requirements (see Chart One).
  4. Cut jumpers JW1 and JW3 on EC-115.

# Warranty & Warning Information

## Warning Please Read Carefully

Note to End Users: This equipment is subject to terms and conditions of sale as follows:

### **Note to Installers**

This warning contains vital information. As the only individual in contact with system users, it is your responsibility to bring each item in this warning to the attention of the users of this system. Failure to properly inform system end-users of the circumstances in which the system might fail may result in over-reliance upon the system. As a result, it is imperative that you properly inform each customer for whom you install the system of the possible forms of failure.

### **System Failures**

This system has been carefully designed to be as effective as possible. There are circumstances, such as fire or other types of emergencies where it may not provide protection. Alarm systems of any type may be compromised deliberately or may fail to operate as expected for a variety of reasons. Some reasons for system failure include:

#### *•Inadequate Installation*

A Fire Alarm system must be installed in accordance with all the applicable codes and standards in order to provide adequate protection. An inspection and approval of the initial installation, or, after any changes to the system, must be conducted by the Local Authority Having Jurisdiction. Such inspections ensure installation has been carried out properly.

#### *•Power Failure*

Control units, smoke detectors and many other connected devices require an adequate power supply for proper operation. If the system or any device connected to the system operates from batteries, it is possible for the batteries to fail. Even if the batteries have not failed, they must be fully charged, in good condition and installed correctly. If a device operates only by AC power, any interruption, however brief, will render that device inoperative while it does not have power. Power interruptions of any length are often accompanied by voltage fluctuations which may damage electronic equipment such as a fire alarm system. After a power interruption has occurred, immediately conduct a complete system test to ensure that the system operates as intended.

#### *•Failure of Replaceable Batteries*

Systems with wireless transmitters have been designed to provide several years of battery life under normal conditions. The expected battery life is a function of the device environment, usage and type. Ambient conditions such as high humidity, high or low temperatures, or large temperature fluctuations may reduce the expected battery life. While each transmitting device has a low battery monitor which identifies when the batteries need to be replaced, this monitor may fail to operate as expected. Regular testing and maintenance will keep the system in good operating condition.

#### *•Compromise of Radio Frequency (Wireless) Devices*

Signals may not reach the receiver under all circumstances which could include metal objects placed on or near the radio path or deliberate jamming or other inadvertent radio signal interference.

#### *•System Users*

A user may not be able to operate a panic or emergency switch possibly due to permanent or temporary physical disability, inability to reach the device in time, or unfamiliarity with the correct operation. It is important that all system users be trained in the correct operation of the alarm system and that they know how to respond when the system indicates an alarm.

#### *•Automatic Alarm Initiating Devices*

Smoke detectors, heat detectors and other alarm initiating devices that are a part of this system may not properly detect a fire condition or signal the control panel to alert occupants of a fire condition for a number of reasons, such

as: the smoke detectors or heat detector may have been improperly installed or positioned; smoke or heat may not be able to reach the alarm initiating device, such as when the fire is in a chimney, walls or roofs, or on the other side of closed doors; and, smoke and heat detectors may not detect smoke or heat from fires on another level of the residence or building.

•*Software*

Most Mircom products contain software. With respect to those products, Mircom does not warranty that the operation of the software will be uninterrupted or error-free or that the software will meet any other standard of performance, or that the functions or performance of the software will meet the user's requirements. Mircom shall not be liable for any delays, breakdowns, interruptions, loss, destruction, alteration or other problems in the use of a product arising out of, or caused by, the software.

Every fire is different in the amount and rate at which smoke and heat are generated. Smoke detectors cannot sense all types of fires equally well. Smoke detectors may not provide timely warning of fires caused by carelessness or safety hazards such as smoking in bed, violent explosions, escaping gas, improper storage of flammable materials, overloaded electrical circuits, children playing with matches or arson.

Even if the smoke detector or heat detector operates as intended, there may be circumstances when there is insufficient warning to allow all occupants to escape in time to avoid injury or death.

•*Alarm Notification Appliances*

Alarm Notification Appliances such as sirens, bells, horns, or strobes may not warn people or waken someone sleeping if there is an intervening wall or door. If notification appliances are located on a different level of the residence or premise, then it is less likely that the occupants will be alerted or awakened. Audible notification appliances may be interfered with by other noise sources such as stereos, radios, televisions, air conditioners or other appliances, or passing traffic. Audible notification appliances, however loud, may not be heard by a hearing-impaired person.

•*Telephone Lines*

If telephone lines are used to transmit alarms, they may be out of service or busy for certain periods of time. Also the telephone lines may be compromised by such things as criminal tampering, local construction, storms or earthquakes.

•*Insufficient Time*

There may be circumstances when the system will operate as intended, yet the occupants will not be protected from the emergency due to their inability to respond to the warnings in a timely manner. If the system is monitored, the response may not occur in time enough to protect the occupants or their belongings.

•*Component Failure*

Although every effort has been made to make this system as reliable as possible, the system may fail to function as intended due to the failure of a component.

•*Inadequate Testing*

Most problems that would prevent an alarm system from operating as intended can be discovered by regular testing and maintenance. The complete system should be tested as required by national standards and the Local Authority Having Jurisdiction and immediately after a fire, storm, earthquake, accident, or any kind of construction activity inside or outside the premises. The testing should include all sensing devices, keypads, consoles, alarm indicating devices and any other operational devices that are part of the system.

•*Security and Insurance*

Regardless of its capabilities, an alarm system is not a substitute for property or life insurance. An alarm system also is not a substitute for property owners, renters, or other occupants to act prudently to prevent or minimize the harmful effects of an emergency situation.

IMPORTANT NOTE: End-users of the system must take care to ensure that the system, batteries, telephone lines, etc. are tested and examined on a regular basis to ensure the minimization of system failure.

## Limited Warranty

Mircom Technologies Ltd. warrants the original purchaser that for a period of two years from the date of manufacture, the product shall be free of defects in materials and workmanship under normal use. During the warranty period, Mircom Technologies Ltd. shall, at its option, repair or replace any defective product upon return of the product to its factory, at no charge for labor and materials. Any replacement and/or repaired parts are warranted for the remainder of the original warranty or ninety (90) days, whichever is longer. The original owner must promptly notify Mircom Technologies Ltd. in writing that there is defect in material or workmanship, such written notice to be received in all events prior to expiration of the warranty period.

## International Warranty

The warranty for international customers is the same as for any customer within Canada and the United States, with the exception that Mircom Technologies Ltd. shall not be responsible for any customs fees, taxes, or VAT that may be due.

## Conditions to Void Warranty

This warranty applies only to defects in parts and workmanship relating to normal use. It does not cover:

- damage incurred in shipping or handling;
- damage caused by disaster such as fire, flood, wind, earthquake or lightning;
- damage due to causes beyond the control of Mircom Technologies Ltd. such as excessive voltage, mechanical shock or
- water damage;
- damage caused by unauthorized attachment, alterations, modifications or foreign objects;
- damage caused by peripherals (unless such peripherals were supplied by Mircom Technologies Ltd.);
- defects caused by failure to provide a suitable installation environment for the products;
- damage caused by use of the products for purposes other than those for which it was designed;
- damage from improper maintenance;
- damage arising out of any other abuse, mishandling or improper application of the products.

## Warranty Procedure

To obtain service under this warranty, please return the item(s) in question to the point of purchase. All authorized distributors and dealers have a warranty program. Anyone returning goods to Mircom Technologies Ltd. must first obtain an authorization number. Mircom Technologies Ltd. will not accept any shipment whatsoever for which prior authorization has not been obtained. NOTE: Unless specific pre-authorization in writing is obtained from Mircom management, no credits will be issued for custom fabricated products or parts or for complete fire alarm system. Mircom will at its sole option, repair or replace parts under warranty. Advance replacements for such items must be purchased.

Note: Mircom Technologies Ltd.'s liability for failure to repair the product under this warranty after a reasonable number of attempts will be limited to a replacement of the product, as the exclusive remedy for breach of warranty.

## Disclaimer of Warranties

This warranty contains the entire warranty and shall be in lieu of any and all other warranties, whether expressed or implied (including all implied warranties of merchantability or fitness for a particular purpose) And of all other obligations or liabilities on the part of Mircom Technologies Ltd. neither assumes nor authorizes any other person purporting to act on its behalf to modify or to change this warranty, nor to assume for it any other warranty or liability concerning this product.

This disclaimer of warranties and limited warranty are governed by the laws of the province of Ontario, Canada.

## **Out of Warranty Repairs**

Mircom Technologies Ltd. will at its option repair or replace out-of-warranty products which are returned to its factory according to the following conditions. Anyone returning goods to Mircom Technologies Ltd. must first obtain an authorization number. Mircom Technologies Ltd. will not accept any shipment whatsoever for which prior authorization has not been obtained.

Products which Mircom Technologies Ltd. determines to be repairable will be repaired and returned. A set fee which Mircom Technologies Ltd. has predetermined and which may be revised from time to time, will be charged for each unit repaired.

Products which Mircom Technologies Ltd. determines not to be repairable will be replaced by the nearest equivalent product available at that time. The current market price of the replacement product will be charged for each replacement unit.

**WARNING: Mircom Technologies Ltd. recommends that the entire system be completely tested on a regular basis. However, despite frequent testing, and due to, but not limited to, criminal tampering or electrical disruption, it is possible for this product to fail to perform as expected.**

**NOTE: Under no circumstances shall Mircom Technologies Ltd. be liable for any special, incidental, or consequential damages based upon breach of warranty, breach of contract, negligence, strict liability, or any other legal theory. Such damages include, but are not limited to, loss of profits, loss of the product or any associated equipment, cost of capital, cost of substitute or replacement equipment, facilities or services, down time, purchaser's time, the claims of third parties, including customers, and injury to property.**

**MIRCOM MAKES NO WARRANTY OF MERCHANTABILITY OR FITNESS FOR A PARTICULAR PURPOSE WITH RESPECT TO ITS GOODS DELIVERED, NOR IS THERE ANY OTHER WARRANTY, EXPRESSED OR IMPLIED, EXCEPT FOR THE WARRANTY CONTAINED HEREIN.**





## Notes

---



